

Specifications

Nominal Voltage(V)

12V

Nominal Capacity

20 hour rate	(2.25A to 10.50V)	45Ah
10 hour rate	(4.275A to 10.50V)	42.75Ah
5 hour rate	(7.65A to 10.20V)	38.25Ah
1 C	(45A to 9.60V)	25.5Ah
3 C	(135A to 9.60V)	18Ah

Weight

Approx. 14.5kg(31.9Lbs.)

Internal Resistance (at 1KHz)

Approx. 7 mΩ

Maximum Discharge Current for

5 seconds: 540A

Charging Methods at 25°C(77°F)

Cycle use:	
Charging Voltage	14.4 to 15.0V
Coefficient	-5.0mV/°C/cell
Maximum Charging Current :	13.5A
Standby use:	
Float Charging Voltage	13.5 to 13.8V
Coefficient	-3.0mV/°C/cell

Operating Temperature Range

Charge	-15°C(5°F)	to	40°C(104°F)
Discharge	-15°C(5°F)	to	50°C(122°F)
Storage	-15°C(5°F)	to	40°C(104°F)

Charge Retention (shelf life) at 20°C(68°F)

1 month	92%
3 month	90%
6 month	80%

Case Material

ABS UL94 HB
Option: Flammability resistance of (UL94 V-0)

Design Life

3-5 Years.

Terminal

F4



Dimensions

Length (L)

199⁺³₋₁ (7.83^{+0.12}_{-0.04})

Width (W)

166⁺³₋₁ (6.54^{+0.12}_{-0.04})

Height (H)

171⁺³₋₁ (6.73^{+0.12}_{-0.04})

Overall Height (HT)

171⁺³₋₁ (6.73^{+0.12}_{-0.04})

mm(inch)

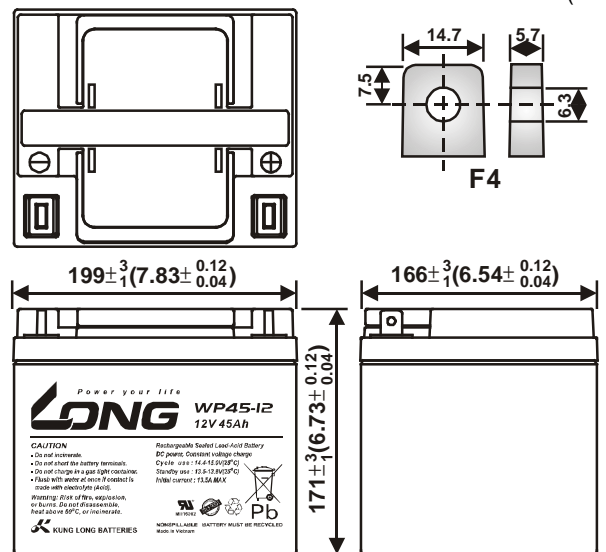

(V) FOR 12V BATTERY Discharge Time VS. Discharge Current (25°C)

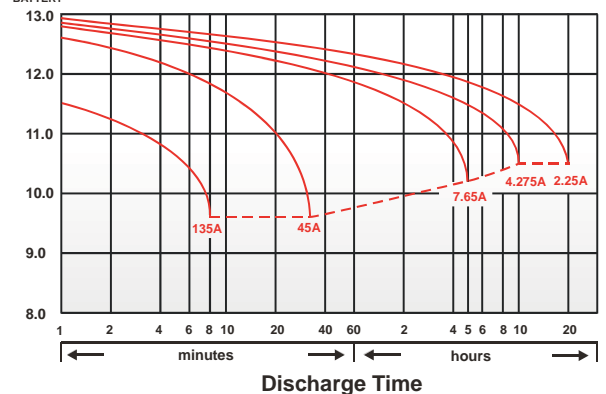

Effect of Temperature on Capacity 25°C (77°F)

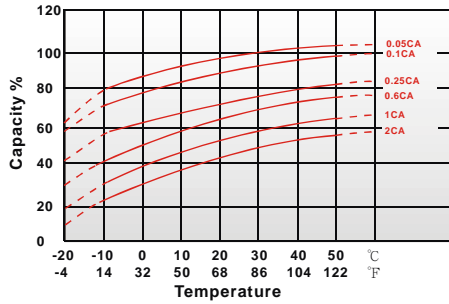

Capacity Retention Characteristic

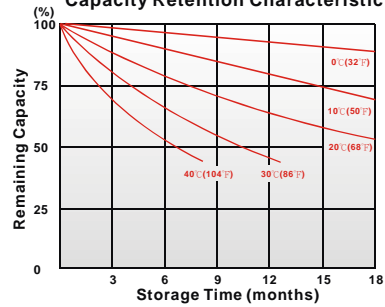

Cycle Service Life

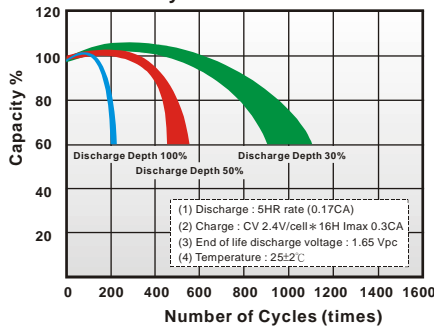

Trickle (or float) Service Life

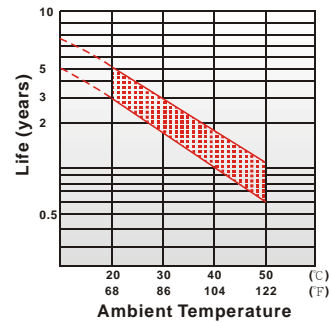

- PERFORMANCE DATA

Discharge Rates in Watts to Various End Voltages at 25°C (77°F)

End Voltage		1.85V	1.80V	1.75V	1.70V	1.67V	1.65V	1.60V
Time								
5	min	233	280	314	336	341	347	354
10	min	148	178	200	214	217	221	225
15	min	116	136	150	159	162	164	167
30	min	62.0	73.0	80.5	85.4	86.5	88.1	89.4
60	min	48.8	51.8	53.6	54.9	55.3	55.9	56.4
120	min	25.7	27.3	28.2	28.9	29.2	29.5	29.7
180	min	20.5	21.8	22.5	23.1	23.2	23.5	23.7
240	min	16.4	17.4	18.0	18.4	18.7	18.8	19.0
300	min	14.0	14.9	15.4	15.7	15.9	16.0	16.2
600	min	8.23	8.74	9.04	9.26	9.35	9.44	9.52
1200	min	4.34	4.61	4.76	4.88	4.93	4.98	5.02

- Discharge Rates in Amperes to Various End Voltages at 25°C (77°F)

End Voltage		1.85V	1.80V	1.75V	1.70V	1.67V	1.65V	1.60V
Time								
5	min	127	153	171	183	186	190	193
10	min	79.5	95.6	107	114	116	118	121
15	min	60.3	71.0	78.3	83.1	84.2	85.6	87.0
30	min	31.7	37.3	41.1	43.6	44.2	45.0	45.7
60	min	24.6	26.1	27.0	27.7	27.9	28.2	28.4
120	min	12.9	13.7	14.2	14.6	14.7	14.8	14.9
180	min	10.3	10.9	11.3	11.5	11.6	11.8	11.9
240	min	8.20	8.70	9.00	9.22	9.31	9.40	9.48
300	min	6.97	7.40	7.65	7.84	7.91	7.99	8.06
600	min	4.10	4.35	4.50	4.61	4.65	4.70	4.74
1200	min	2.15	2.28	2.36	2.42	2.44	2.47	2.49

All data on the spec. sheet is an average value:

The tolerance range : $X < 6\text{min}$ (+15%~-15%), $6\text{min} \leq X < 10\text{min}$ (+12%~-12%), $10\text{min} \leq X < 60\text{min}$ (+8%~-8%), $X \geq 60\text{min}$ (+5%~-5%)

120219-1J