

Overview of plastic clamps



Plastic clamps

	Abranyl® AN	Abranyl® ABT	Abranyl® ABM	Multiclip MC	Multiclip UT
Diameter Ø (mm)	12-50	14-42	10-42	16-40	16-40
Base	Nylon	Nylon	Nylon	Polypropylene	Nylon
Temperature range °C	-10°C to +90°C (at peaks of -25°C to +110°C)	-10°C to +90°C (at peaks of -25°C to +110°C)	-10°C to +90°C (at peaks of -25°C to +110°C)	-20°C to +100°C (at peaks of -30°C to +120°C)	-10°C to +90°C (at peaks of -25°C to +110°C)
Tension load (kg)	60	60	60	10	10
Halogen free	✓	✓	✓	✓	✓
RoHS compliant	✓	✓	✓	✓	✓
KIWA approval	✓	✓	✓	✗	✗
UL certificate	✗	✓	✗	✗	✗
Patented clamp	✗	✓	✓	✗	✗
Absorption of stretching	✓	✓	✓	✗	✗
Multidiameter	✓ 2 diameters per size except for Ø 10, 12, 14	✓ 3 diameters per size	✓ 3 diameters per size	✗	✗
Fast installation with:	Nail plug NP	Gas nailer FORCE ONE and FOX	Tacomax®	Nail plug NP	Gas nailer FORCE ONE and FOX
Mounting with metric thread	✓ M6	✗	✓ with Insermax®	✗	✗
Parallel mounting possible	✗	✗	✗	✓	✓
Applications	Electrical and sanitary	Electrical and sanitary	Electrical and sanitary	Electrical	Electrical
page	268	268	269	270	271

Pipe ring clip

UT

Advantages





- Fast installation with gas nailer FORCE ONE & FOX
- Also compatible with gas nailer Powers Trak It® C3, Spit Pulsa 700E/800E
- UT clips can be mounted in series due to lateral slots
- A marking allows quick alignment
- Halogen free
- RoHS compliant

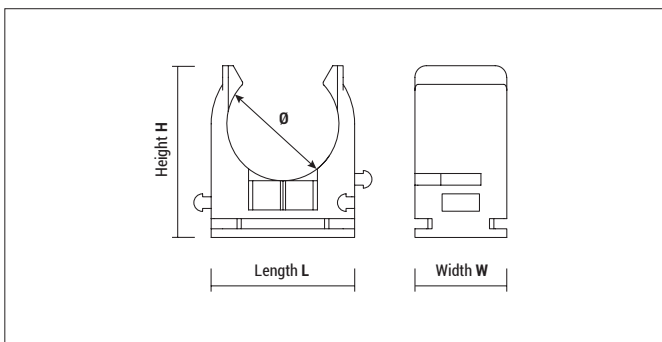

Mounting



UT

Type	Art-No	Pipe-Ø Plastic [mm]	€ / 100 pcs	 [pcs]	 [pcs]
UT 16	916UT	16		100	900
UT 20	920UT	20		100	900
UT 25	925UT	25		100	900
UT 32	932UT	32		50	450
UT 40	940UT	40		50	300

Approvals and certificates



Type	Ø [mm]	Length L [mm]	Height H [mm]	Width W [mm]
UT 16	16	23,0	25,5	16
UT 20	20	25,0	29,5	16
UT 25	25	30,5	34,0	16
UT 32	32	38,0	42,0	16
UT 40	40	46,0	50,0	16